

Tools Required:

- 4mm hex key
- 11/32" nut driver
- Phillips head screw driver medium

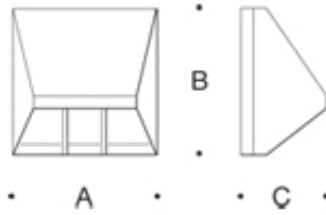

Dimensions

- A: 7 7/8 "
- B: 7 7/8 "
- C: 4 1/2 "



Protection Class: IP65
Weight: 4.0 lbs

Notice to Installer for 22 256:

1. For wall applications only.
2. Mounts directly to standard recessed 4" wiring box (by others) using mounting kit (provided).
3. In conformance with UL Standard 1598, a silicone based sealant must be used between luminaire and supporting wall.
4. LEDs are high-quality electronic components! Please avoid touching the light output opening of the LED directly during installation.

22 256 - installation:

1. Loosen (4) 4mm housing hex screws and remove outer casting with lens attached.
2. Feed luminaire wires through fixture base, IP nipple, and center hole in mounting strap.
3. Make supply wiring and luminaire wiring connections inside the octagonal wiring box:
 MAIN VOLTAGE SUPPLY WIRE TO BLACK LUMINAIRE WIRE
 NEUTRAL (COMMON) SUPPLY WIRE TO WHITE LUMINAIRE WIRE
 GREEN GROUND WIRE TO GREEN LUMINAIRE WIRE
 Dimming (if applicable):
 DIMMING CONTROL WIRE (+) TO POSITIVE DRIVER DIM CONTROL WIRE
 DIMMING CONTROL WIRE (-) TO NEGATIVE DRIVER DIM CONTROL WIRE
4. Attach mounting strap (provided) to wiring box using outlet box screws (by others).
5. Attach 1/4" nipple to mounting strap (provided) and place luminaire over nipple.
 NOTE: Place a small bead of silicone around the back side of the luminaire base that will come in contact with the finished wall (exterior applications only).
6. Use lockwasher and nut (provided) to secure luminaire on nipple. Tighten screw.
7. Replace outer casting and tighten (4) housing screws, making sure the gasket is sealed properly.

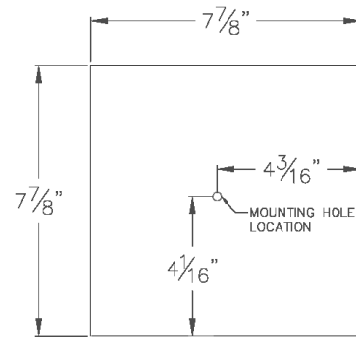
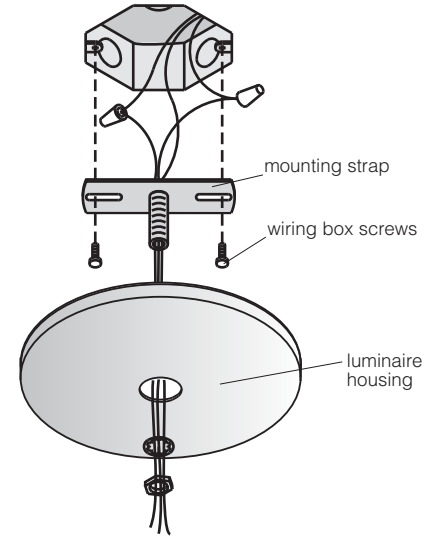

Relamping/Maintenance

No relamping required.

Accessories

Please refer to the appropriate accessory installation sheet for further instruction when applicable.

Replacement Parts

Description	Part No
Face Plate	FP2256
LED Driver	75940
LED Module (3000K)	LED-0281/830A
LED Module (4000K)	LED-0281/840A

Lamp: 17.8W LED Module

In the interest of product improvement, BEGA reserves the right to make technical changes without notice.

Product Safety Warnings:

THIS PRODUCT MUST BE INSTALLED IN ACCORDANCE WITH THE APPLICABLE INSTALLATION CODE BY A PERSON FAMILIAR WITH THE CONSTRUCTION AND OPERATION OF THE PRODUCT AND THE HAZARDS INVOLVED. SUITABLE FOR WET LOCATIONS.

MIN 90°C SUPPLY CONDUCTORS.

CE PRODUIT DOIT ÊTRE INSTALLÉ SELON LE CODE D'INSTALLATION PERTINENT, PAR UNE PERSONNE QUI CONNAÎT BIEN LE PRODUIT ET SON FONCTIONNEMENT AINSI QUE LES RISQUES INHÉRENTS. CONVIENT AUX EMPLACEMENTS MOUILLÉS.

LES FILS D'ALIMENTATION 90°C MIN.
