

Tools Required:

- 4mm hex head screwdriver

Overview:

Weight: 4.0 lbs.

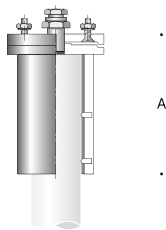

Dimensions

A: 6 3/4"

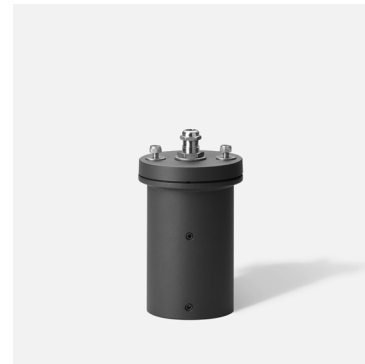

Notice to Installer:

1. See page 2 for specific product safety warnings.
2. For use with yoke mounted floodlights only - see website for compatible products.
3. For use with 3" outer diameter pole or tenon only. Tenon length must be 4" minimum.

70 342 installation:

1. Install yoke mounted floodlight to top of pole cap as shown in Figure 1.
2. Guide cable through water-tight compression fitting and tighten to secure. Wiring connections to be made in pole, see specific floodlight installation instructions for additional details
3. Loosen (6) 4mm set screws and slip fit pole cap over 3" OD pole or tenon, routing cable into pole for wiring connections.
4. Tighten (6) 4mm set screws to 12 Nm to secure pole cap in place.

Figure 1:

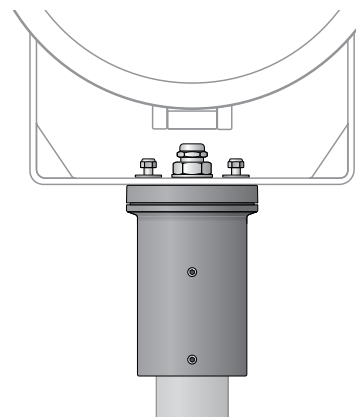

Accessories

Please refer to the appropriate accessory installation sheet for further instruction when applicable.

Maintenance:

Clean regularly with solvent-free cleaner removing dirt and debris. Do not use high pressure cleaners.

Replacement Parts

See label inside of fixture for LED replacement part number.

Consult factory for all other replacement components.

Product Safety Warnings:

THIS PRODUCT MUST BE INSTALLED IN ACCORDANCE WITH THE APPLICABLE INSTALLATION CODE BY A PERSON FAMILIAR WITH THE CONSTRUCTION AND OPERATION OF THE PRODUCT AND THE HAZARDS INVOLVED.

CE PRODUIT DOIT ÊTRE INSTALLÉ SELON LE CODE D'INSTALLATION PERTINENT, PAR UNE PERSONNE QUI CONNAÎT BIEN LE PRODUIT ET SON FONCTIONNEMENT AINSI QUE LES RISQUES INHÉRENTS.