

**Tools Required:**

- 5mm hex key
- Drill
- Phillips head screwdriver

**Protection Class:** IP 65

**Weight:** 167.1 lbs



**Dimensions**

- A:** 10-3/8"
- B:** 34-3/8"



**Notice to Installer for 84 303:**

1. See page 2 for specific product safety warnings.
2. Fixture may be damaged if connected to conduit systems that contain water
  - Article 300-5G of the National Electric Code requires that "Conduits or raceway through which moisture may contact energized live parts shall be sealed or plugged at either or both ends."
3. For proper installation, an accompanying bollard head must be selected with the bollard tube.
4. Wet location listing does not imply suitability for exposure to standing water for long periods of time.
5. The bollard tube and anchorage unit are designed in conjunction with a foundation that must be constructed on site (see note below).
  - Note: The anchor base is designed to fit with the closest domestic steel beam available - W6x25. Consult factory for additional details.**

**84 303 Concrete Foundation:**

**NOTE: See concrete pouring instructions 01525 (included). The size of the foundation depends on the topography and the soil properties and must be decided on site. CONSULT STRUCTURAL ENGINEER FOR FOUNDATION DETAILS. CONSTRUCTION DRAWINGS FOR REFERENCE ONLY. PLANS ARE ONLY VALID WHEN USED IN CONJUNCTION WITH STRUCTURAL PLANS, AS DETERMINED BY A QUALIFIED PROFESSIONAL.**

1. Create the sub-base and foundation slab.
2. Create the rebar and steel beam foundation in accordance with concrete pouring instructions 01525 (included).
3. Install the conduit and guide it through the anchorage unit.
4. Secure the anchorage unit in place using washers and nuts as outlined in the construction documents. Make sure the anchorage unit tube is absolutely vertical.
5. When pouring concrete; fill anchorage unit with concrete up to, but not over, the bollard tube attachment points.

**WARNING: DO NOT OVER FILL.**

**84 303 Bollard Tube Installation:**

**NOTE: The bollard tube cannot be below finished grade.**

1. Remove mounting bolts and washers from the anchorage unit.
2. Place bollard housing over anchorage unit and tighten bolts firmly.
3. Spacer washers included for dimensional deviations (+/- 0.5") of the paved surface area.
4. Lead the supply cable into the provided connection box and make wiring connections.
5. Make supply wiring connections inside the connection box:
  - MAIN VOLTAGE SUPPLY WIRE TO BLACK CABLE WIRE
  - NEUTRAL (COMMON) SUPPLY WIRE TO WHITE CABLE WIRE
  - GREEN GROUND WIRE TO GREEN CABLE WIRE
 Dimming (if applicable):
  - DIMMING CONTROL WIRE (+) TO POSITIVE CABLE WIRE
  - DIMMING CONTROL WIRE (-) TO NEGATIVE CABLE WIRE
6. Install bollard head per specific bollard head installation instructions.

Figure 1:

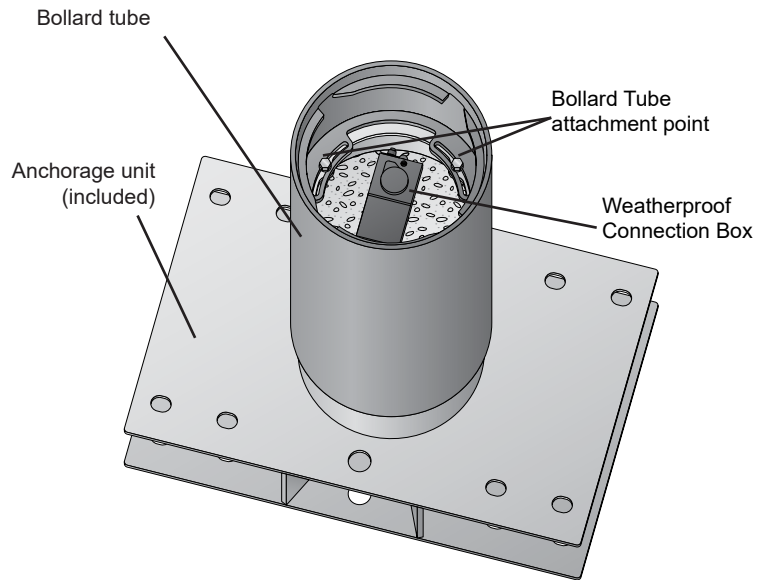
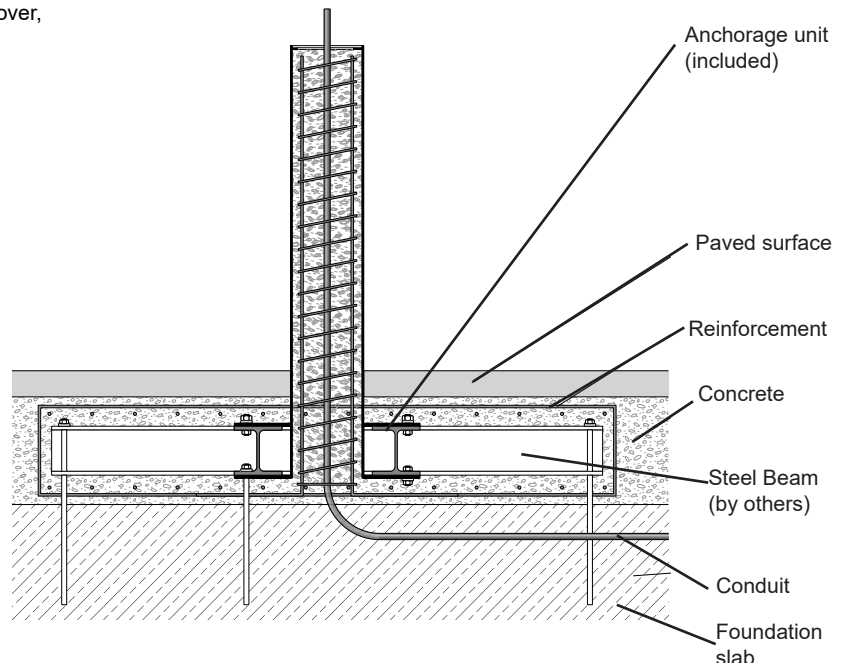

Figure 2:



In the interest of product improvement, BEGA reserves the right to make technical changes without notice.

## Product Safety Warnings:

**THIS PRODUCT MUST BE INSTALLED IN ACCORDANCE WITH THE APPLICABLE INSTALLATION CODE BY A PERSON FAMILIAR WITH THE CONSTRUCTION AND OPERATION OF THE PRODUCT AND THE HAZARDS INVOLVED. SUITABLE FOR WET LOCATIONS.**

**MIN 90°C SUPPLY CONDUCTORS.**

**CE PRODUIT DOIT ÊTRE INSTALLÉ SELON LE CODE D'INSTALLATION PERTINENT, PAR UNE PERSONNE QUI CONNAÎT BIEN LE PRODUIT ET SON FONCTIONNEMENT AINSI QUE LES RISQUES INHÉRENTS. CONVIENT AUX EMPLACEMENTS MOUILLÉS.**

**LES FILS D'ALIMENTATION 90°C MIN.**

---